

# TIGER AUDIO

By CLEIDIMAR, TIGER AUDIO  
GOIANIA GOIAS



## Box Properties

--Description--

Name:

Type: Vented Box

Shape: Prism, square

--Box Parameters--

Vb = 40, liters

V(total) = 45,89 liters

Fb = 40,72 Hz

QL = 7,

F3 = 34,62 Hz

Fill = none

--Vents--

No. of Vents = 1

Vent shape = round

Vent ends = one flush

Dv = 100, mm

Lv = 270, mm

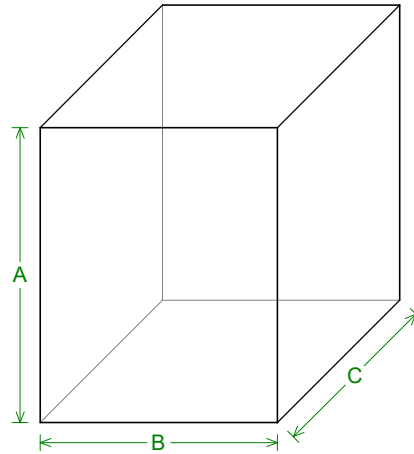

--External Dimensions--

A = 460, mm

B = 370, mm

C = 360, mm

--Internal Dimensions--

A = 424, mm

B = 334, mm

C = 324, mm

--Wall Thickness--

Front = 18, mm

Side = 18, mm

## Driver Properties

--Description--

Name: 12 800W

Type: Standard one-way driver

Company: TIGER AUDIO

Comment: CLEIDIMAR FERREIRA

Piston: CELULOSE

Suspension: ESPUMA

Dust Cap: ABS

Frame: ALUMINIO

Voice Coil: CCAW

Terminals: BORNE PRESSAO

Magnet: 169/45

--Configuration--

**No. of Drivers = 1**

--Driver Parameters--

Fs = 36,34 Hz

Vas = 30, liters

Xmax = 16, mm

Sd = 0,049 sq.m

Re = 4, ohms

Le = 1,9 mH

Z = 4, ohms

BL = 16,23 Tm

Pe = 800, watts

Qts = 0,77

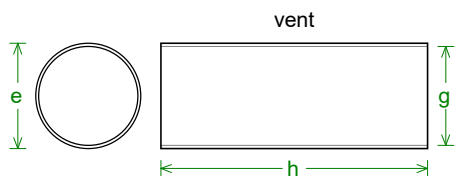
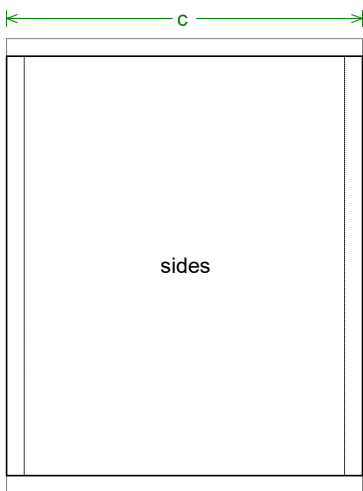
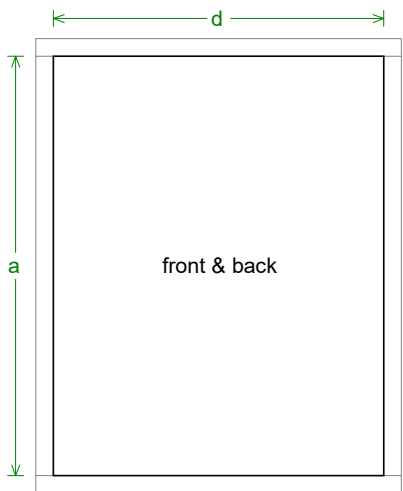
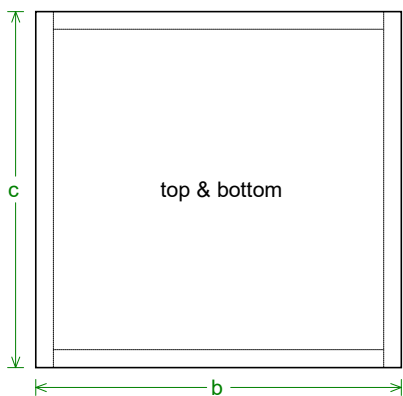

### Box Parts

- Box Shape: Square Prism
- 1 Top, 1 Bottom: depth (c) = 360, mm  
width (b) = 370,, thickness = 18, mm
- 1 Front, 1 Back: height (a) = 424, mm  
width (d) = 334,, thickness = 18, mm
- 2 Sides: height (a) = 424, mm  
depth (c) = 360,, thickness = 18, mm

--Driver Mounting--  
Mounting: Flush

- Vent Parts--
- 1 Duct: outside diameter (e) = 106,4 mm  
inside diameter (g) = 100, mm  
length (h) = 270, mm

